



PRECAST, PRESTRESSED HOLLOW CORE SLABS DESIGN CRITERIA & SPAN-LOAD CHARTS



Introduction	2
Design Criteria for Development of the Span-Load Charts	2
Related Publications	3
Manufacturing Tolerances	4
8" Bare Hollow Core Span-Load Chart	5
8" Topped Hollow Core Span-Load Chart	6
12" Bare Hollow Core Span-Load Chart	7
12" Topped Hollow Core Span-Load Chart	8
12½" Bare Hollow Core Span-Load Chart	9
8" Hollow Core Residual Camber	10
12" Hollow Core Residual Camber	11
General Notes	12
Blockouts	13
Allowable Ripped Slab Widths	14
Dimensions for Detailing	15
Dimensions for Safe Drilling	16



INTRODUCTION

The Hollow Core slab is manufactured in a standard 4' width and 8", 12" and 12½" thicknesses using a continuous concrete extrusion process. Zero-slump, high-strength concrete with a 28-day strength in excess of 8,000 psi and ½" diameter, 270 ksi, low relaxation steel strands are used in the process. The strands are pretensioned and fully bonded to the concrete to support the slabs under design loads. When the concrete reaches sufficient strength to bond the strands, the slabs are cut from the extrusion to customer-specified lengths. Narrow-width slabs are available at additional cost by rip-cutting standard width slabs. Economical layout of the slabs utilizes as many of the standard 4' wide units as possible with the remainder of the layout filled with non-standard width slabs or cast-in-place closure strips. Contact CTC's Marketing Department for special considerations and limitations.

The Hollow Core slab has a variety of uses, including floors and roofs for buildings and parking garages, decks for piers and short-span bridges, lids for storm water detention vaults, and lagging for retaining walls. Cast-in-place, composite concrete topping may be added to provide a smooth, level floor surface that serves as a horizontal diaphragm when properly reinforced. For untopped and non-composite topping applications, the horizontal diaphragm is provided by shear friction reinforcement in the grouted shear keys and in the end closure pours.

The following Span-Load Charts show the 8" and 12" sizes with and without a minimum 2½" thick composite topping. The 12½" size with topping is not shown as it is usually used in untopped applications. It is designed with a thicker top flange to provide the greater durability and increased "punch-through" capacity normally supplied by the topping.

DESIGN CRITERIA FOR DEVELOPMENT OF THE SPAN-LOAD CHARTS

ATTENTION: The Span-Load Charts were derived from computer-calculated data, are intended as an aid to preliminary sizing, and must be interpreted using sound engineering judgment.

The Span-Load Charts were developed as described below:

ALLOWABLE STRESSES – The extreme fiber stress under full service load is limited to $0.45f'_c$ for compression and $12\sqrt{f'_c}$ for tension in accordance with ACI 318-14 for Class U or Class T prestressed concrete flexural members.

FLEXURAL STRENGTH – The nominal flexural strength, ϕM_n , exceeds the required factored moment, $M_u = 1.2M_d + 1.6M_l$, in accordance with ACI 318-14, Sections 5.3.1 & 7.5.1.1(a). The strength reduction factor, ϕ , is calculated per Sections 21.2.1 through 21.2.3. The stress in the pretensioned reinforcement at nominal strength (f_{ps}) is calculated in accordance with Sections 25.4.8 and 20.3.2.3.1, and all superimposed load is considered as live load. Where flexural strength governs the design, superimposed loads comprised of dead and live load combinations will increase the capacity over the values given in the Span-Load Charts.

SHEAR – The nominal shear strength, ϕV_n , exceeds the required factored shear, $V_u = 1.2V_d + 1.6V_l$, in accordance with ACI 318-14, Sections 5.3.1 and 7.5.1.1(b). Web shear strength (V_{cw}) is calculated in accordance with CTA Technical Bulletin 85B1. This method determines the applied shear which causes a principal tension of $4\sqrt{f'_c}$ at the centroid of the pretensioned member, as allowed in ACI 318-14, Section 22.5.8.3.3. Flexure shear strength (V_{ci}) is calculated as set forth in CTA Technical Bulletin 78B1. This method uses a modified version of Equation (22.5.8.3.1a) of ACI 318-14, based on full-scale testing of Hollow Core slabs.

Filling a predetermined number of voids with cast-in-place concrete will result in higher web shear capacity in the transfer zone at the ends of the slabs. Contours in the Span-Load Charts indicate the number of voids filled with 3,000 psi concrete (typically to 2' from the face of support) to achieve the given capacity. The capacity of the filled voids is discussed in CTA Technical Bulletin 85B1.

All values in the Span-Load Charts are based on Hollow Core slabs without shear reinforcement. It is not possible to provide shear reinforcement in extruded Hollow Core slabs.



COMPOSITE CAST-IN-PLACE TOPPING – Full-scale load tests performed at Concrete Technology Corporation have verified that, for composite Hollow Core systems with factored horizontal shear stresses between the topping and slab of 90 psi or less, full composite action is achieved without intentionally roughening the top surface or providing mechanical ties. This is discussed in CTA Technical Bulletins 74B6 and 76B4. The composite Span-Load Charts are capped with a bold contour where horizontal shear would otherwise govern. Contact CTC's Marketing Department for further information concerning test results or special design conditions.

The weight of the cast-in-place topping has already been included in determining the allowable superimposed load on composite slabs. Do not deduct the weight of the topping from the values derived from the Span-Load Charts.

The natural camber of the Hollow Core slabs, combined with the wet weight of the cast-in-place topping, will normally require a variable thickness of topping to provide a flat finished floor. Residual Camber Contour charts are provided to estimate the amount of residual camber or sag after placement of the topping. The weight of the variable thickness in addition to the 2½" minimum has been considered in the development of the Span-Load Charts.

FIRE RESISTANCE RATING – The fire resistance rating of Hollow Core slabs can be calculated using methods in chapter 10 of the PCI Design Handbook, 7th Edition (MNL-120-10).

DEFLECTIONS – Total deflection is defined as the upward camber of the slab due to the eccentricity of the pretensioning less the downward deflection due to applied loads, including the long-term effects of prestress loss, creep and shrinkage. Allowable loads from the Span-Load Charts limit the theoretical total deflection to $l/180$. In addition, the deflection due to prestress and dead load, including long-term effects, is limited to $l/240$. Instantaneous deflections due to live loads are limited to $l/360$. The load combinations considered in the deflection analysis are 50% dead and live load, or 100% live load.

Associated building elements that may be affected by deflections should be placed with adequate tolerances. It is not practical to deflect the formwork to produce desired cambers. Suggested methods for calculating cambers and deflections are described in the 7th Edition of the PCI Design Handbook, Section 5.8. Contact CTC's Marketing Department with any questions about deflections.

ROUGH OPENINGS – The values in the Span-Load Charts apply to Hollow Core slabs without openings. Rough openings through the voided area of a Hollow Core slab normally have little effect on its load-carrying capacity. However, large openings that cut webs and strands can have a significant impact on the load-carrying capacity of the slab. Contact CTC's Marketing Department with questions on the capacity of slabs with openings.

RELATED PUBLICATIONS AVAILABLE FROM CTC

- Guide Specifications for Precast, Prestressed Hollow Core Slabs
- Hollow Core Slab Connection Details
- Field Handling and Erection of Hollow Core Slabs
- Concrete Technology Corporation Research Reports:

CTA Technical Bulletin 73B6, "Shear Diaphragm Capacity of Precast Floor Systems"

CTA Technical Bulletin 74B6, "Composite Systems Without Roughness"

CTA Technical Bulletin 75B10/11, "Flexural Bond Performance"

CTA Technical Bulletin 76B3, "Non-Destructive Testing of Concrete"

CTA Technical Bulletin 76B4, "Composite Systems Without Ties"

CTA Technical Bulletin 78B1, "Shear Strength of Hollow Core Members"

CTA Technical Bulletin 79B4, "Shear Strength of Continuous Hollow Core Systems"

CTA Technical Bulletin 80B3, "Shear Diaphragm Capacity of Untopped Hollow Core Floor Systems"

CTA Technical Bulletin 82B2, "Grouting Precast Floor Systems"

CTA Technical Bulletin 85B1, "Web Shear Strength of Prestressed Concrete Members"



MANUFACTURING TOLERANCES

- a = Length ± 1 in.
- b = Width $\pm 1/4$ in.
- c = Depth $\pm 1/4$ in.

d_t = Top of flange thickness
 Top flange area defined by the actual measured values of average $d_t \times b$ shall not be less than 85% of the nominal area calculated by d_t nominal $\times b$ nominal.

d_b = Bottom flange thickness
 Bottom flange area defined by the actual measured values of average $d_b \times b$ shall not be less than 85% of the nominal area calculated by d_b nominal $\times b$ nominal.

e = Web thickness
 The total cumulative web thickness defined by the actual measured value Σe shall not be less than 85% of the nominal cumulative width calculated by Σe nominal.

f = Rough Opening ± 2 in.

g = Flange angle 1/8 in. per 12 in., 1/2 in. max.

h = Variation from specified end squareness or skew $\pm 1/2$ in.

i = Sweep (variation from straight line parallel to centerline of member) $\pm 3/8$ in.

j = Center of gravity of strand group
 The CG of the strand group relative to the top of the slab shall be within $\pm 1/4$ in. of the nominal strand group CG.

The position of any individual strand shall be within $\pm 1/2$ in. of nominal vertical position and $\pm 3/4$ in. of nominal horizontal position and shall have a minimum cover of 3/4 in.

k = Local smoothness $\pm 1/4$ in. in 10 ft.

l = Applications requiring close control of differential camber between adjacent members of the same design should be discussed in detail with the producer to determine applicable tolerances.

Slab Weight

Excess concrete material in the slab internal features is within tolerance as long as the measured weight of the individual slab does not exceed 110% of the nominal published unit weight used in the load capacity calculation.

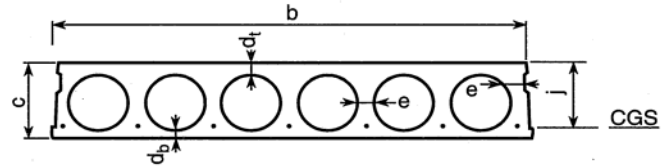

CROSS SECTION

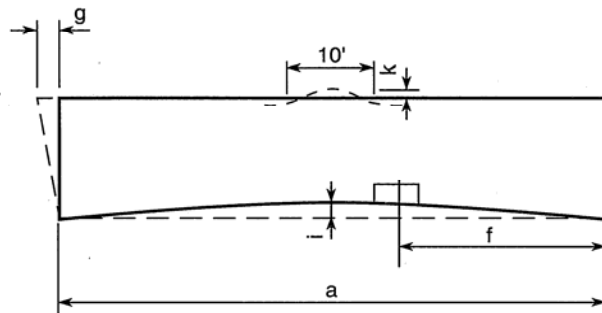

PLAN

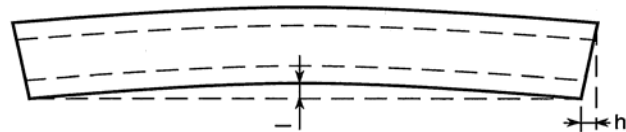

ELEVATION



8" HOLLOW CORE SLAB

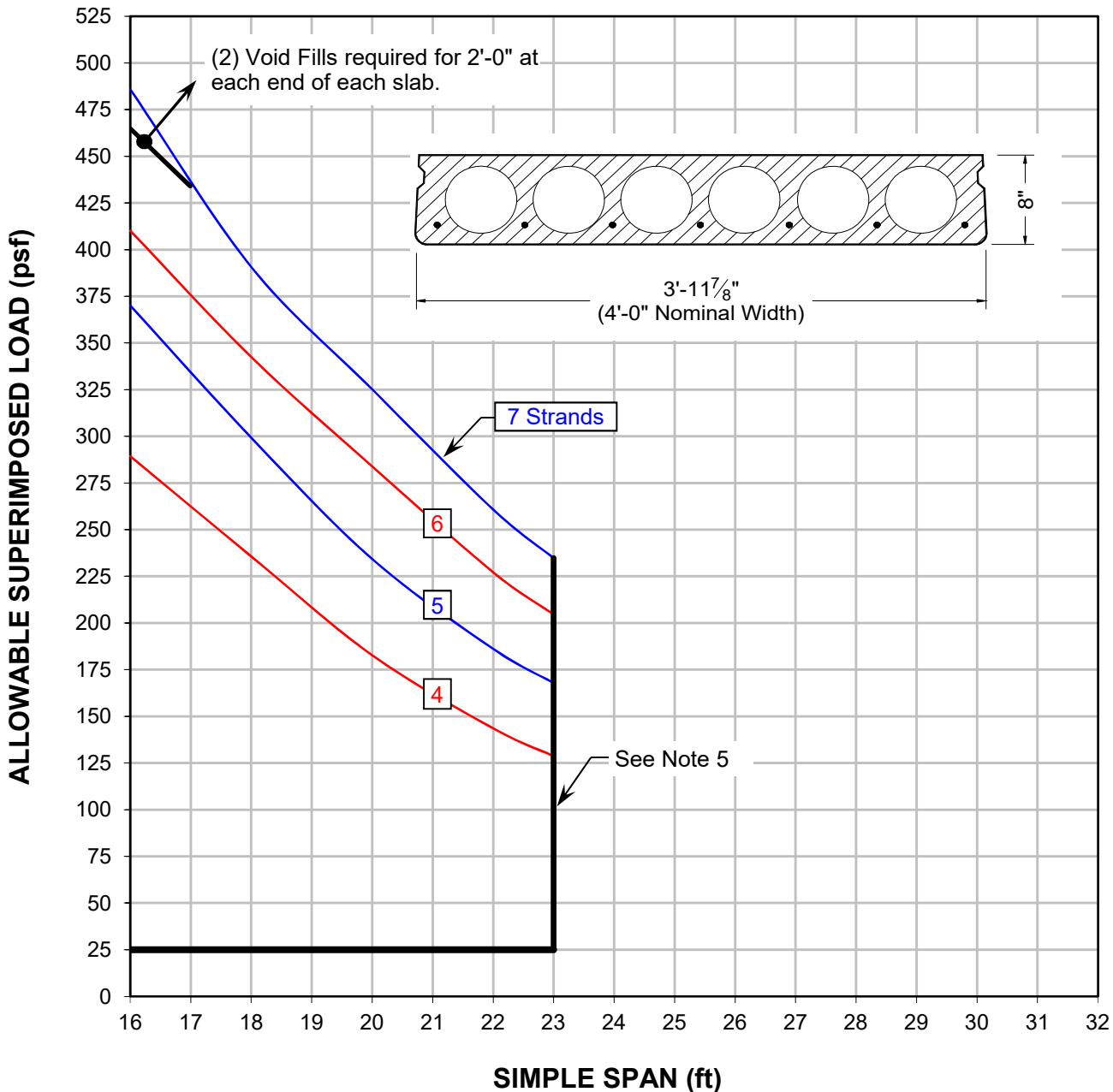

SECTION PROPERTIES (with shear key grouted)

$I = 1,666 \text{ in}^4$	$S_t = 417 \text{ in}^3$	$S_b = 417 \text{ in}^3$	$A = 214 \text{ in}^2$
$w = 57 \text{ psf}$	$y_t = 4.00 \text{ in}$	$y_b = 4.00 \text{ in}$	$e = 2.25 \text{ in}$

NOTES:

1. The values given in this chart are in compliance with ACI 318-19.
2. The values given in this chart are based on hollow core slabs without shear reinforcement. See [SHEAR](#) for discussion.
3. Refer to [DEFLECTIONS](#) for discussion of deflection criteria.
4. This Span-Load Chart is intended as an aid to preliminary sizing only, and must be interpreted using sound engineering judgment.
5. Maximum allowable span lengths are based on a span-to-depth ratio of 35 unless otherwise approved by the manufacturer.



8" HOLLOW CORE SLAB COMPOSITE WITH 2½" CONCRETE TOPPING

f'_c topping = 4,000 psi

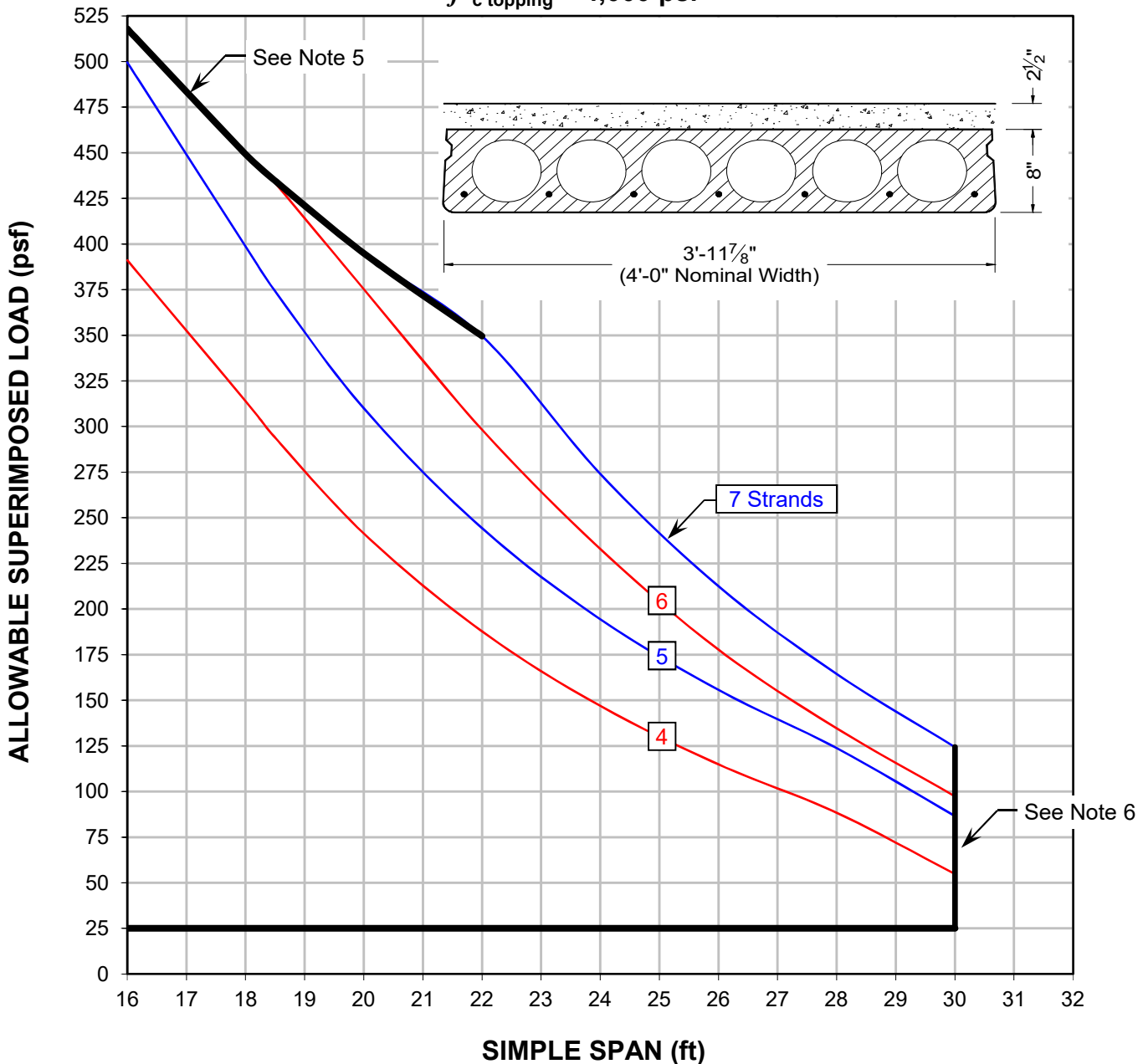

COMPOSITE SECTION PROPERTIES (with shear key grouted)

$I_c = 3,336 \text{ in}^4$	$S_{tc} = 972 \text{ in}^3$	$S_{bc} = 612 \text{ in}^3$	$S_{if} = 1,308 \text{ in}^3$
$w = 90 \text{ psf}$	$y_{tc} = 5.05 \text{ in}$	$y_{bc} = 5.45 \text{ in}$	$y_{if} = 2.55 \text{ in}$

NOTES:

1. The values given in this chart are in compliance with ACI 318-19.
2. The values given in this chart are based on hollow core slabs without shear reinforcement. See [SHEAR](#) for discussion.
3. Refer to [DEFLECTIONS](#) for discussion of deflection criteria.
4. This Span-Load Chart is intended as an aid to preliminary sizing only, and must be interpreted using sound engineering judgment.
5. Interface shear governs the design of composite topped hollow core slabs above this line.
6. Maximum allowable span lengths are based on a span-to-depth ratio of 35 unless otherwise approved by the manufacturer.



12" HOLLOW CORE SLAB

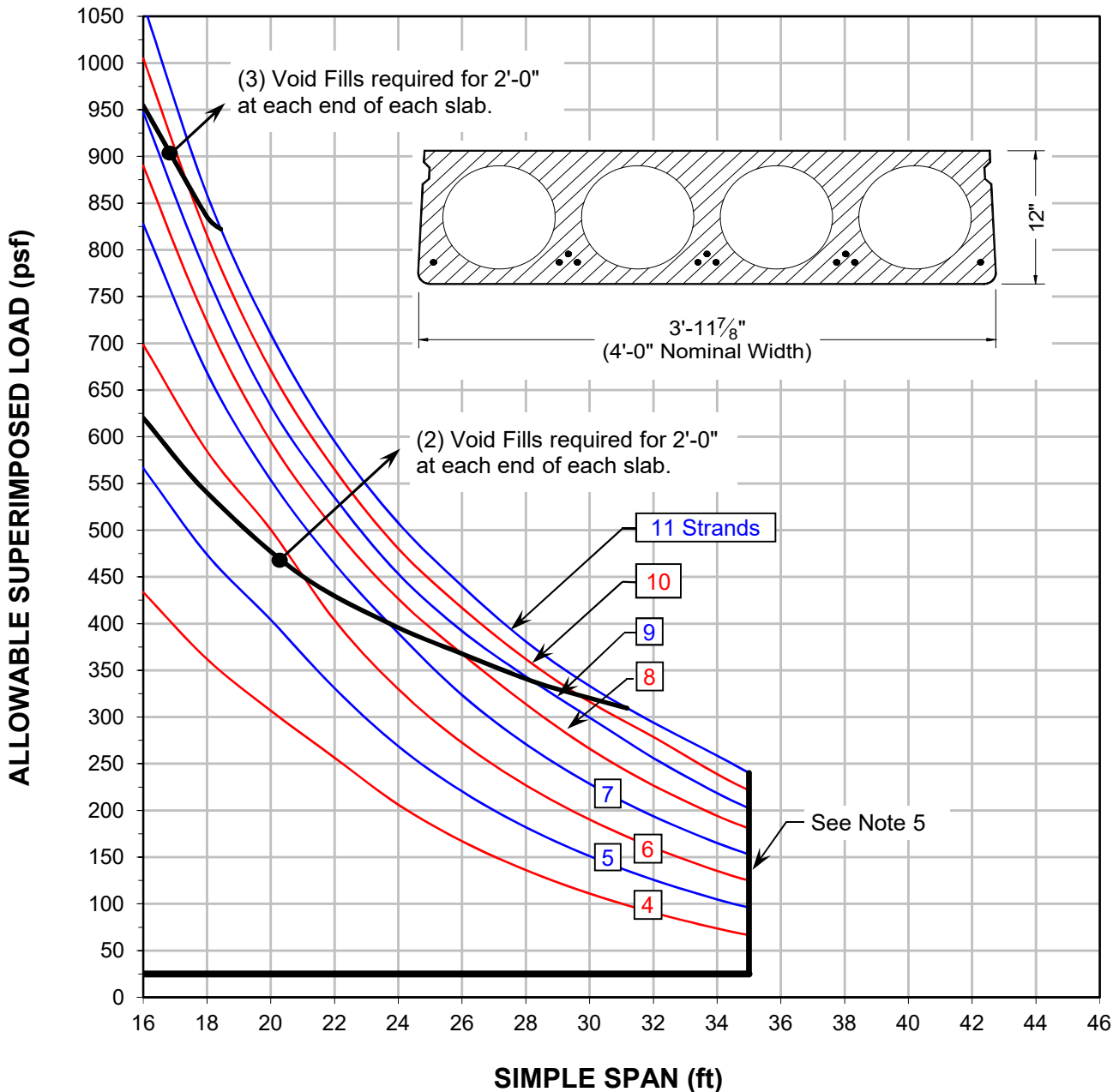

SECTION PROPERTIES (with shear key grouted)

$I = 5,270 \text{ in}^4$	$S_t = 878 \text{ in}^3$	$S_b = 878 \text{ in}^3$	$A = 289 \text{ in}^2$
$w = 77 \text{ psf}$	$y_t = 6.00 \text{ in}$	$y_b = 6.00 \text{ in}$	

NOTES:

1. The values given in this chart are in compliance with ACI 318-19.
2. The values given in this chart are based on hollow core slabs without shear reinforcement. See [SHEAR](#) for discussion.
3. Refer to [DEFLECTIONS](#) for discussion of deflection criteria.
4. This Span-Load Chart is intended as an aid to preliminary sizing only, and must be interpreted using sound engineering judgment.
5. Maximum allowable span lengths are based on a span-to-depth ratio of 35 unless otherwise approved by the manufacturer.



12" HOLLOW CORE SLAB COMPOSITE WITH 2½" CONCRETE TOPPING

f'_c topping = 4,000 psi

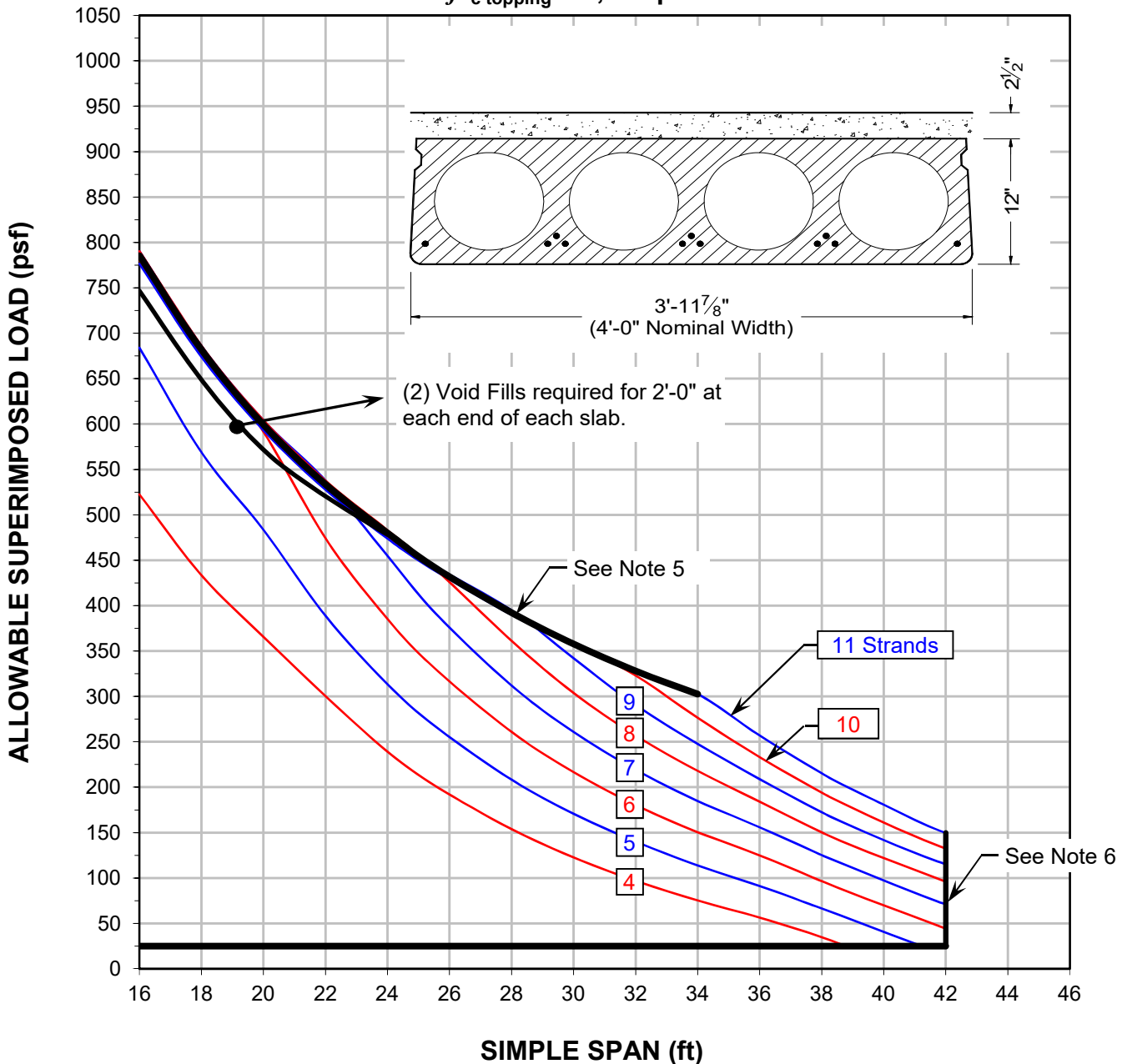

COMPOSITE SECTION PROPERTIES (with shear key grouted)

$I_c = 8,656 \text{ in}^4$	$S_{tc} = 1,844 \text{ in}^3$	$S_{bc} = 1,140 \text{ in}^3$	$S_{if} = 1,965 \text{ in}^3$
$w = 111 \text{ psf}$	$y_{tc} = 6.90 \text{ in}$	$y_{bc} = 7.60 \text{ in}$	$y_{if} = 4.40 \text{ in}$

NOTES:

1. The values given in this chart are in compliance with ACI 318-19.
2. The values given in this chart are based on hollow core slabs without shear reinforcement. See [SHEAR](#) for discussion.
3. Refer to [DEFLECTIONS](#) for discussion of deflection criteria.
4. This Span-Load Chart is intended as an aid to preliminary sizing only, and must be interpreted using sound engineering judgment.
5. Interface shear governs the design of composite topped hollow core slabs above this line.
6. Maximum allowable span lengths are based on a span-to-depth ratio of 35 unless otherwise approved by the manufacturer.



12½" HOLLOW CORE SLAB

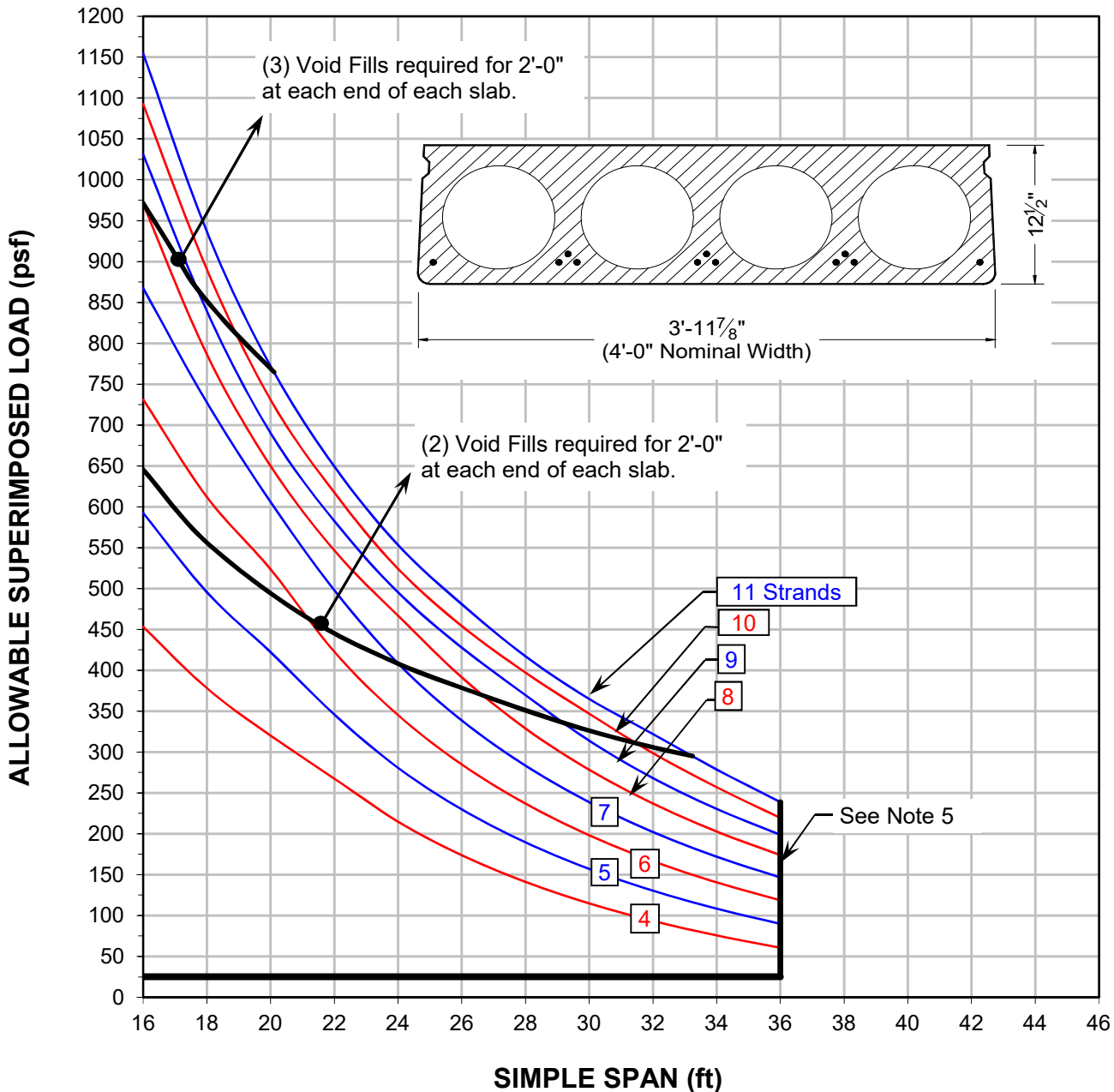

SECTION PROPERTIES (with shear key grouted)

$I = 6,136 \text{ in}^4$	$S_t = 1,019 \text{ in}^3$	$S_b = 947 \text{ in}^3$	$A = 313 \text{ in}^2$
$w = 84 \text{ psf}$	$y_t = 6.02 \text{ in}$	$y_b = 6.48 \text{ in}$	

NOTES:

1. The values given in this chart are in compliance with ACI 318-19.
2. The values given in this chart are based on hollow core slabs without shear reinforcement. See [SHEAR](#) for discussion.
3. Refer to [DEFLECTIONS](#) for discussion of deflection criteria.
4. This Span-Load Chart is intended as an aid to preliminary sizing only, and must be interpreted using sound engineering judgment.
5. Maximum allowable span lengths are based on a span-to-depth ratio of 35 unless otherwise approved by the manufacturer.



ESTIMATED RESIDUAL CAMBER CONTOURS

8" HOLLOW CORE SLAB

COMPOSITE WITH 2½" CONCRETE TOPPING (4,000 psi)

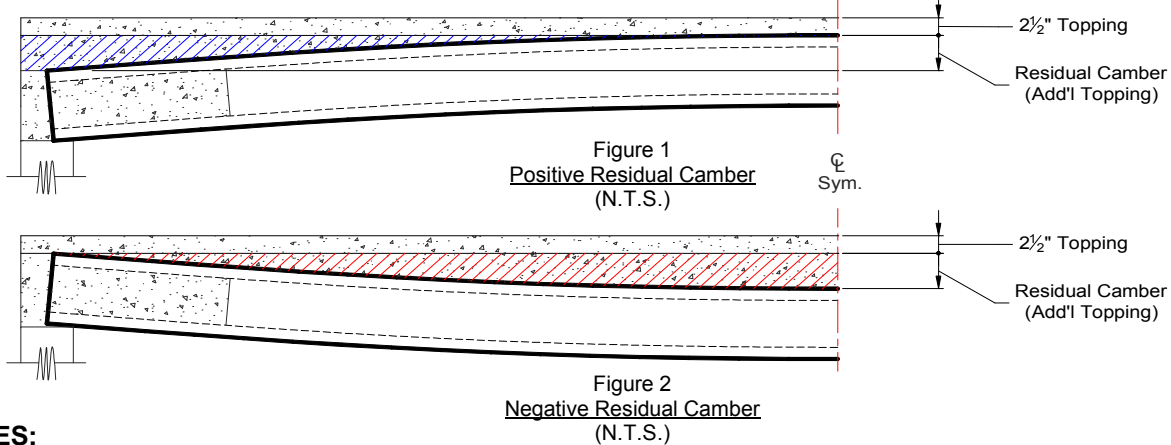
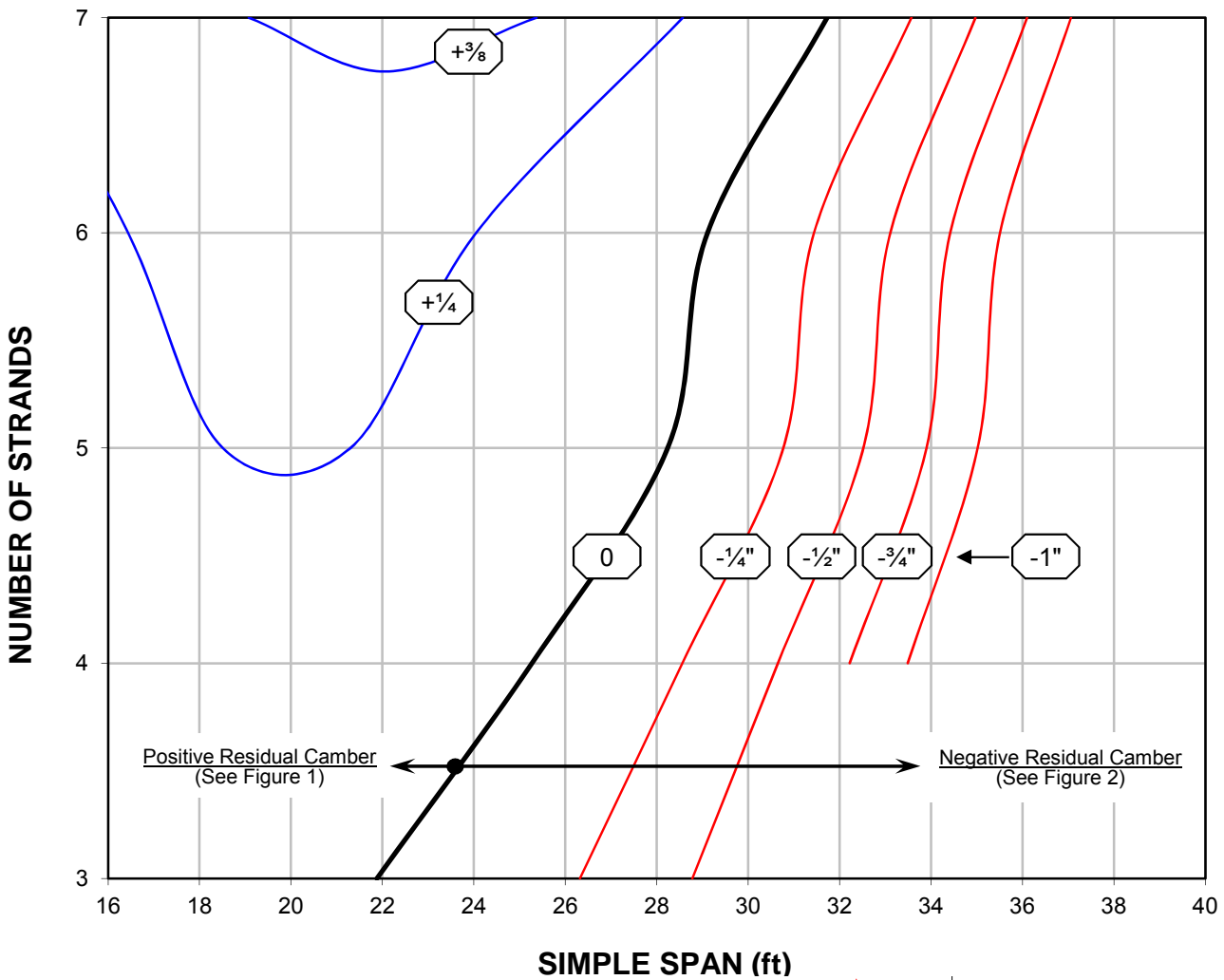

NOTES:

1. Residual Camber is defined as the camber remaining in the hollow core slabs just after the topping slab has been placed. The contours shown above reflect the upward deflection due to prestress force, downward deflection due to the hollow core slab self-weight and downward deflection due to the plastic (wet) topping weight.



ESTIMATED RESIDUAL CAMBER CONTOURS

12" HOLLOW CORE SLAB

COMPOSITE WITH 2½" CONCRETE TOPPING (4,000 psi)

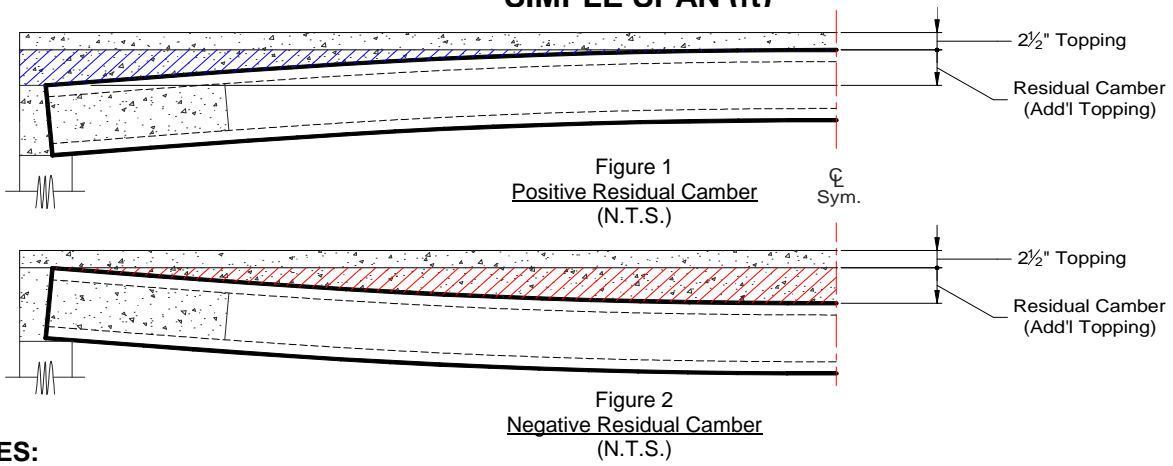
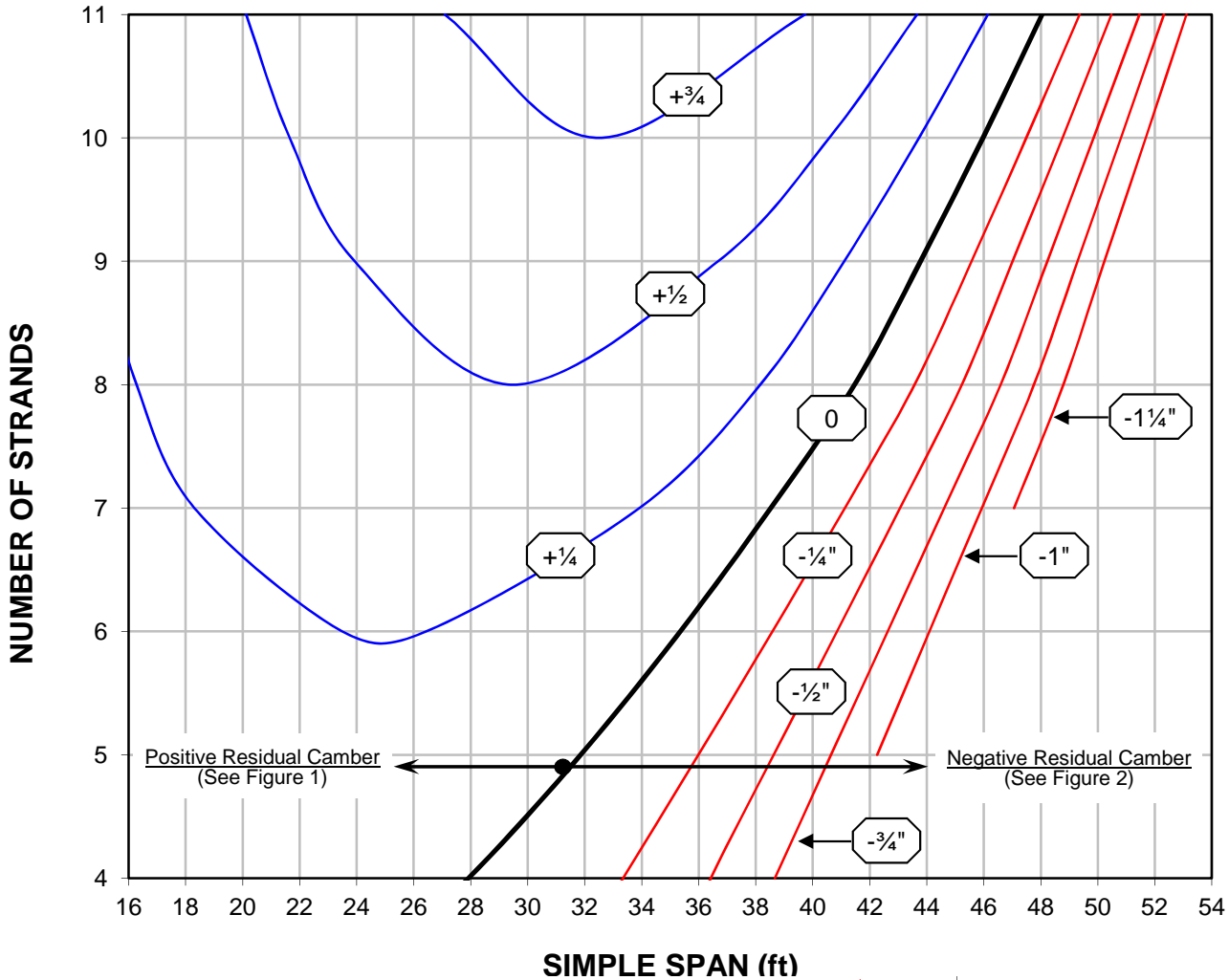

NOTES:

1. Residual Camber is defined as the camber remaining in the hollow core slabs just after the topping slab has been placed. The contours shown above reflect the upward deflection due to prestress force, downward deflection due to the hollow core slab self-weight and downward deflection due to the plastic (wet) topping weight.



GENERAL NOTES

VOID DAMS - Void dams are provided by CTC to restrict the flow of C.I.P. concrete into the slab voids. Typically, the dam is placed six inches from the ends of the slab at voids without pour slots. The dam is placed two feet from the ends of the slab at voids with pour slots. This distance can be modified as required for embedment of reinforcement or to increase the slab end shear strength. To facilitate the placement and consolidation of the concrete fill, CTC recommends and provides blockouts in the top of the voids at locations where endfill length exceeds 1'-6".

BEARING - The recommended design bearing dimension is three inches with a field installation minimum of two inches. CTC recommends and furnishes a 3/8" x 1/4" neoprene end bearing strip to provide uniform bearing during erection. Final bearing is provided when C.I.P. concrete fills the remaining space.

GROUT KEYS - The longitudinal keys between adjacent slabs must be filled with grout to fully develop the concentrated load distribution and shear friction capacity of the Hollow Core slab system. CTC recommends a mix consisting of one (1) part cement to three (3) parts paving or builder's sand by weight, with a maximum water content of five (5) gallons per sack of cement.

RESISTANCE TO LATERAL LOADS - Lateral loads may be transmitted through Hollow Core slabs to resisting elements, such as frames or shear walls, by diaphragm action. When concrete topping is to be installed over the slabs, the diaphragm is normally designed to be in the topping. In this case, shear transfer takes place by shear friction, based on WWF mesh or other reinforcement in the topping. For untopped systems, diaphragm action is developed by means of shear friction reinforcement at the ends of the slabs, as described in CTA Technical Bulletin 80B3. It is important to detail this reinforcement such that it is effectively anchored into the lateral force resisting system, such as by reinforcement hooked into shear walls.

VOID DRAIN HOLES - Void drain holes will be installed in Hollow Core slabs. Cap top holes prior to soil backfill or topping pour to prevent material from washing into void and plugging drains. Drain holes must be cleaned out after end closure concrete pours are complete. The contractor may patch holes, if necessary, once the structure is weather proofed.

CONSTRUCTION LOADS - Once erected, the Hollow Core slabs form a safe platform for workers and normal construction tools. Avoid staging other construction materials on the slabs that have not had the joints grouted and the grout reach design strength. At no time should these materials exceed 1,000 pounds on a single slab or 1,500 pounds on any two adjacent slabs without prior written approval.

PENETRATIONS - CTC recommends that all penetrations less than 6" in diameter for mechanical, plumbing, electrical, etc. be field installed by the trades involved. Prior consultation with the Architect/Engineer and CTC is advisable to insure that the structural capacity of the system is not compromised. CTC recommends that openings larger than 6" be made at time of slab fabrication. Detailing of these openings on the design drawings will aid in the shop drawing/calculation submittal process. Refer to page 13 for design considerations when large openings are used.



BLOCKOUTS

Hollow Core Slabs may be notched to accommodate utilities, drains, through-columns or other items. The figures shown below serve as guidelines that shall be followed when detailing Hollow Core Slabs that require blockouts. Note that the values in the Span-Load Charts apply to Hollow Core Slabs WITHOUT blockouts. Rough openings through the voided area of a Hollow Core Slab normally have little effect on its load-carrying capacity. However, large blockouts that cut webs and strands can have a significant impact on the load-carrying capacity of the slab. Contact CTC's Marketing Department with questions regarding the capacity of Hollow Core Slabs with blockouts.

CASE 1: Blockout ≤ 1'-10" Wide

The maximum width of a blockout in any one Hollow Core Slab shall not exceed 1'-10".

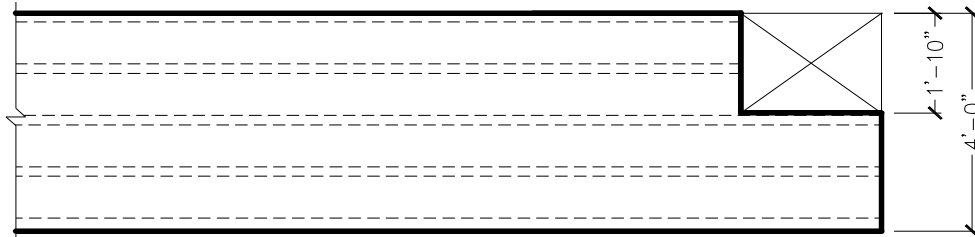

CASE 2: Blockout > 1'-10" Wide

Hollow Core Hangers may be used to accommodate blockouts greater than 1'-10" wide. It is important to recognize that the hung slab imparts additional loading to the adjacent supporting slabs. The adjacent supporting slabs must be evaluated on a case by case basis to determine if they can support the additional loading imparted by the hung slab. Contact CTC's Marketing Department with questions regarding the capacity of the Hollow Core Slab & Hanger system.

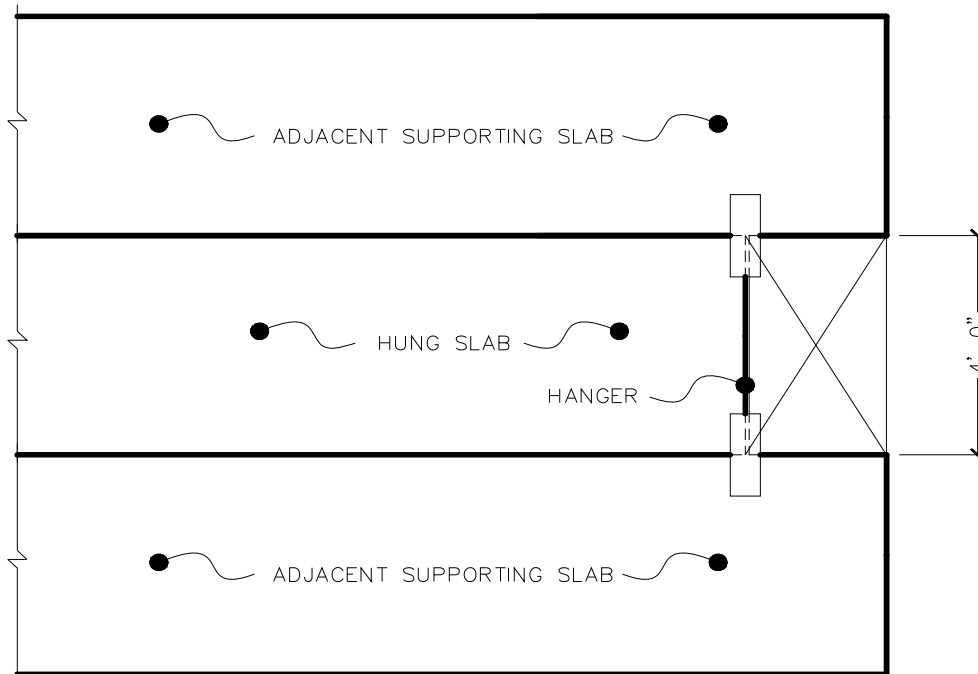



ALLOWABLE RIPPED SLAB WIDTHS

Narrow-width slabs are available at additional cost by rip-cutting standard width slabs. Refer to the guidelines below for allowable ranges of ripped slab widths. Note that not all partial width slabs are available due to safety concerns during handling and erection.

12" & 12½" ULTRASPAN

WIDTH < 2'-2" UNACCEPTABLE

2'-2" ≤ WIDTH ≤ 2'-7" ACCEPTABLE

2'-7" < WIDTH < 3'-1½" UNACCEPTABLE

3'-1½" ≤ WIDTH ≤ 3'-6½" ACCEPTABLE

3'-6½" < WIDTH < 4'-0" UNACCEPTABLE

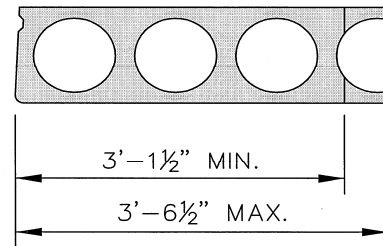
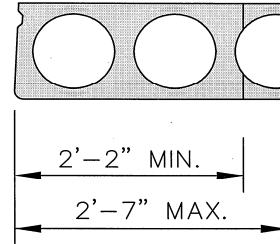

8" ULTRASPAN

WIDTH < 1'-6" UNACCEPTABLE

1'-6" ≤ WIDTH ≤ 1'-9" ACCEPTABLE

1'-9" < WIDTH < 2'-1½" UNACCEPTABLE

2'-1½" ≤ WIDTH ≤ 2'-4½" ACCEPTABLE

2'-4½" < WIDTH < 2'-8½" UNACCEPTABLE

2'-8½" ≤ WIDTH ≤ 2'-11½" ACCEPTABLE

2'-11½" < WIDTH < 3'-4" UNACCEPTABLE

3'-4" ≤ WIDTH ≤ 3'-7" ACCEPTABLE

3'-7" < WIDTH < 4'-0" UNACCEPTABLE

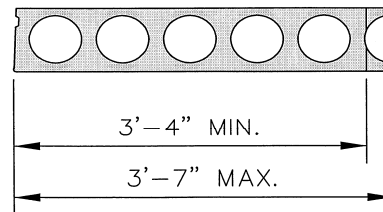
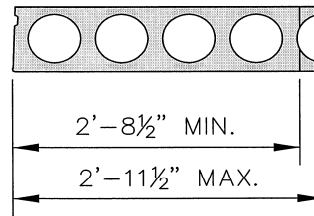
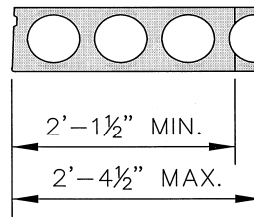
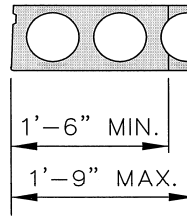



DIMENSIONS FOR DETAILING

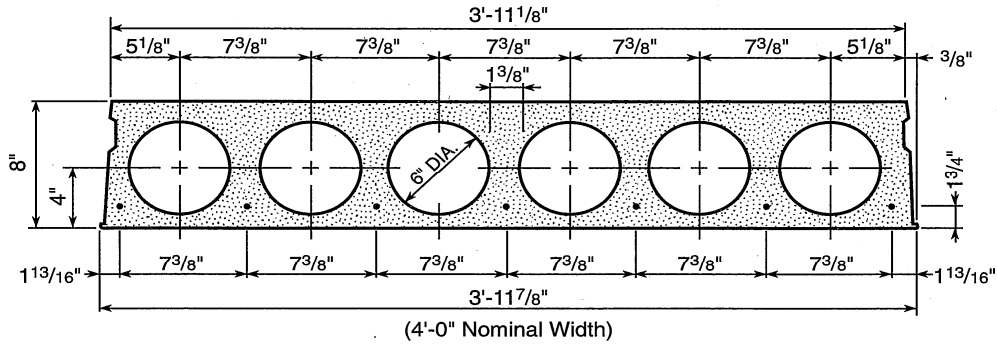

8" ULTRASPAN

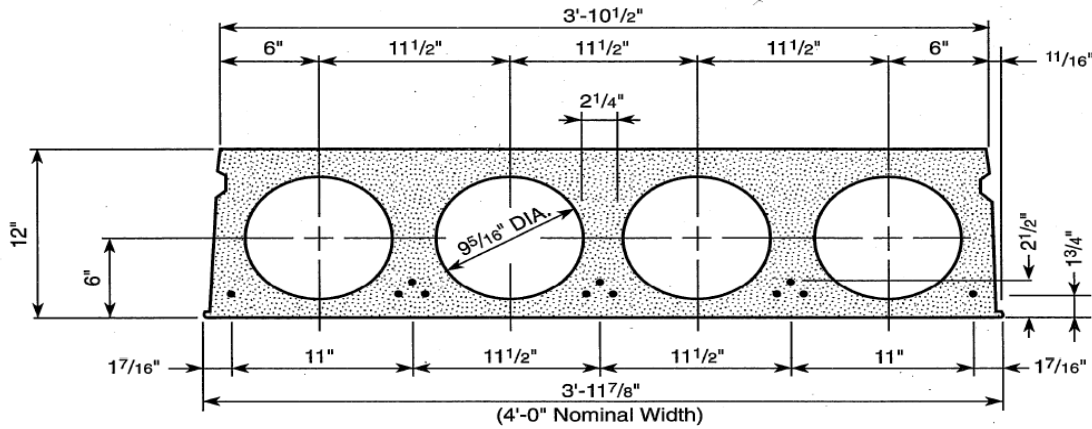

12" ULTRASPAN

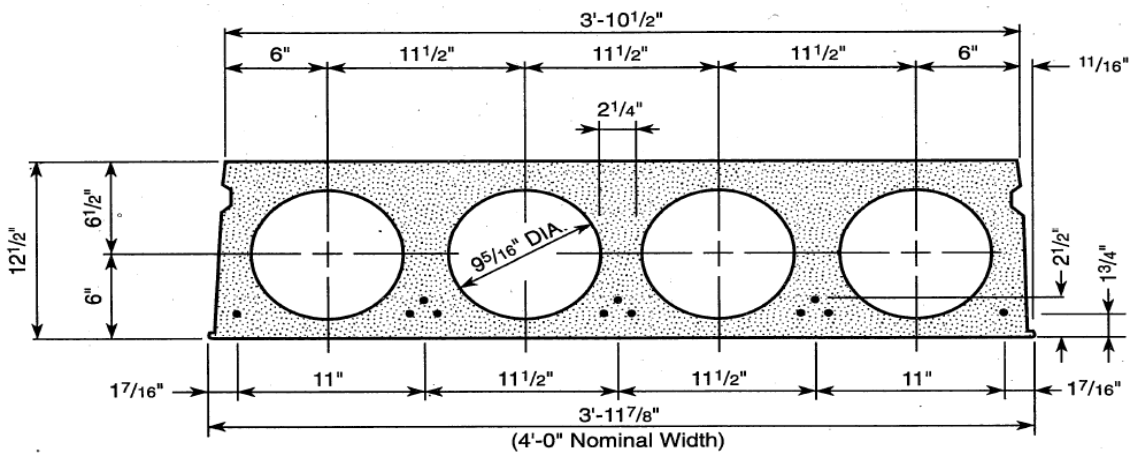

12 1/2" ULTRASPAN



DIMENSIONS FOR SAFE DRILLING

LEGEND  = NO DRILLING

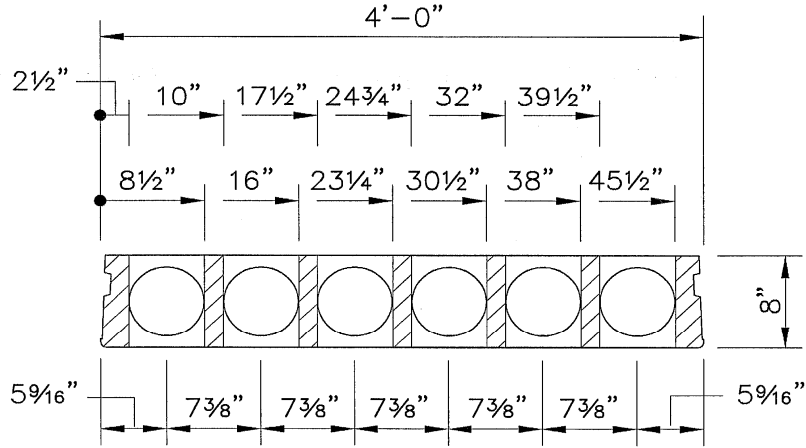

8" ULTRASPAN

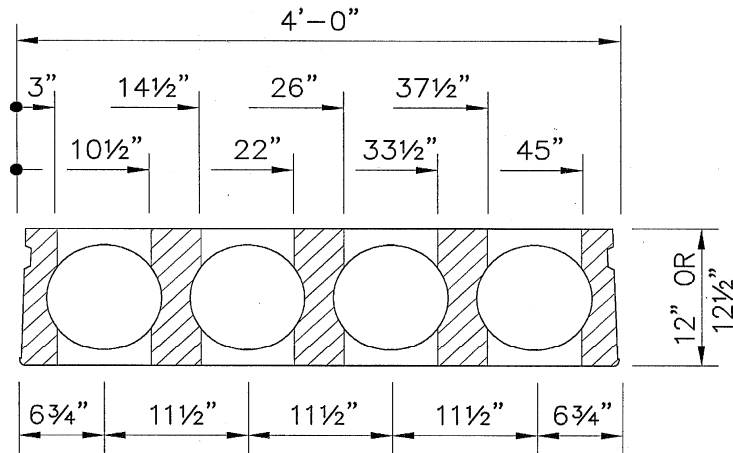

12" & 12 1/2" ULTRASPAN